

This paper was recommended for publication in revised form by Co-Editor Yasin Karagoz

AN OVERVIEW OF BATTERY ELECTRIC VEHICLES AND PLUG-IN HYBRID ELECTRIC VEHICLES

***Ahmet NUR**

Adiyaman University
 Dept. of Electrical and Electronics Engineering
 Adiyaman, Turkey

Keywords: Electric Vehicles, Battery Electric Vehicles, Plug-in Hybrid

** Corresponding author: Phone: +90 416 223 38 00 - 4841, Fax: : +90 416 223 38 42*

E-mail address: anur@adiyaman.edu.tr

ABSTRACT

The depletion of fossil resources, the increase of carbon emissions and the studies of smart transportation technology have increased the importance of electric vehicles. Today, Europe and United States have been started to encourage the use of electric vehicles. Battery Electric Vehicles (BEVs) and Plug-in Hybrid Electric Vehicles (PHEVs) run on a battery and electric drive train. These vehicles will become an alternative for conventional vehicles in the future. This study presents the technological properties of BEVs and PHEVs with some comparisons.

INTRODUCTION

Electric vehicles are taken the drive power from one or more electric motors. Due to strong acceleration characteristics and instantaneous torque, electric motors are increasingly used in the automotive industry [1]. The first electric vehicle model in the world was built in 1835 in the Netherlands by Professor Stratingh. Between the years 1834 and 1836, the electric vehicle development and implementation of the road were reported by Thomas Davenport in the United States. This vehicle was driven by non-rechargeable batteries and was a three-wheeled vehicle. After 1859 the lead-acid batteries have been developed and used. Many companies in the Europe and

the United States began producing and selling the electric vehicle in the 1890s [2, 3].

Electric vehicles in the mid-19th century and early 20th century were extremely popular. In 1901, "New York Taxi" company was started to use electric vehicle as taxis as shown in figure 1. Krieger tested the electric-gasoline hybrid vehicle configuration model for the first time. The first experimental hybrid electric vehicle was designed by Ferdinand Porsche. The vehicle has been named Mixte Wagen [4].



Figure 1: New York taxi service [5]

Before the 1920s, electric vehicles were to compete in quality with the use of petroleum-fueled vehicles. Afterwards, the wide variety of petroleum vehicle, loading the energy in the developed oil infrastructure quickly, companies such as Ford Motor Company serial petroleum vehicle production caused the petroleum vehicle to be cheaper than electric vehicle. As a result of these developments, the electric vehicle was withdrawn in the 1930s from the U.S. market. Until 1960, electric vehicle development studies have not been conducted [6, 7].

After the 1990 with newly battery technology, many vehicles company began to develop electric-vehicle models such as; Ford-Think City, Nissan Altra EV and the Peugeot 106-Electric. Models of the Toyota Prius in Japan in 1997, developed and launched the modern hybrid electric vehicles. 2 years later, the Honda Insight hybrid electric vehicle was made in America and it was followed by the Honda Civic [8]. Currently, the world famous automobile companies attach more importance to the electric vehicles. With the vehicles driving principle, electric vehicle can be divided into three types, including battery electric vehicle, hybrid electric vehicle and fuel-cell electric vehicle [9].

BATTERY ELECTRIC VEHICLES (BEVS)

Battery electric vehicles are pure electric vehicles. These vehicles are powered by electricity stored in large batteries and produce zero emissions at the point of usage. Therefore, these vehicles could be named as zero emission vehicles. In order to recapture energy these vehicles also use regenerative braking system that allows the electric motor to act as a generator. There are two types of battery electric vehicles as shown figure 2. The key difference of between these types is the size of the electric motor and the motor position. Currently, more common type is the central motor. The hub motor type is more suitable for smaller vehicles [10-12].

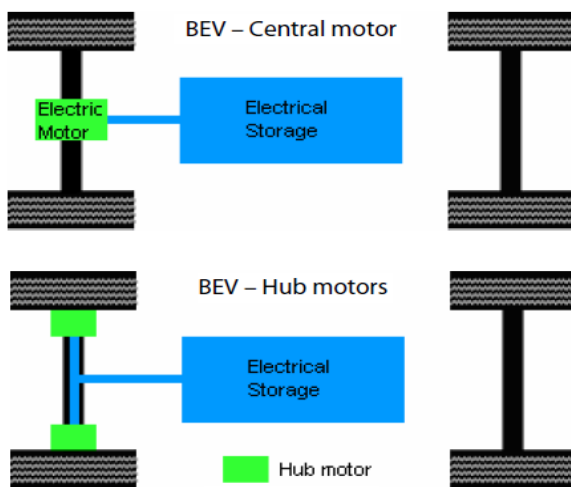

Figure 2: Types of the battery electric vehicles [11]

Battery electric vehicles have some advantages and disadvantages [4, 13]. The advantages are;

- ✓ The batteries are charged from the main supply and the recovery of energy during the braking.
- ✓ They operate silently because of the only electric motor.
- ✓ The fuel and maintenance costs are much less compared to conventional vehicles.
- ✓ Brake life is longer due to regenerative braking system.
- ✓ Charging is possible at home, office etc.
- ✓ Zero emissions at point of usage.

The disadvantages include;

- ✓ High cost of production and therefore the sales price.
- ✓ Poor service stations and a small number of trained technical staff.
- ✓ Low performance due to the heavy battery.
- ✓ Long charging time.

PLUG-IN HYBRID ELECTRIC VEHICLES (PHEVS)

Plug-in hybrid electric vehicles are powered by two sources. It has both an internal combustion engine (ICE) and the electric motor. ICE is used in high-speed driving. The electric motor is used in acceleration, hill climbing and other high power demand. The batteries are charged from the electricity grid. Plug-in hybrid electric vehicles have two main design configurations, including series hybrid and parallel hybrid as shown in figure 3 [14, 15].

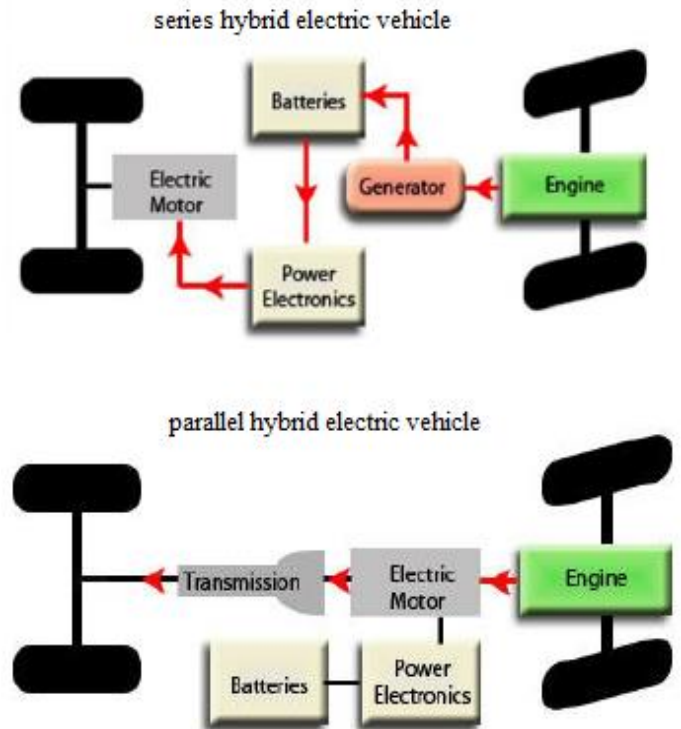

Figure 3: Types of the plug-in hybrid electric vehicles [14]

The vehicles generally have various equipments such as converters (inverters), the battery group, supercapacitors, ICE, electrical machinery (motor / generator), motor drives, battery charger, power distribution and control unit. In series hybrid system, the drive power is transferred to the wheels, which is provided by the electric motor. The electric motor converts electrical power into mechanical power. The electrical power required for the electric motor is supplied from the electric drive system. In parallel hybrid system the electric motor is propelled both the ICE and the electric drive system [16, 17].

Plug-in hybrid electric vehicles have some advantages and disadvantages [18, 19]. The advantages are;

- ✓ Acceleration support with electric motor
- ✓ An increase in the ability to go uphill
- ✓ Quiet driving
- ✓ Comfort and sufficient electrical power for luxury vehicles
- ✓ A tax advantage in some countries
- ✓ Expansion of vehicle stability and control space

The disadvantages include;

- ✓ Due to the battery technology yet to be developed low useful battery cycle life
- ✓ The useful volume depletion, the increase in the vehicle mass
- ✓ An increase in the vehicle complexity
- ✓ Cost increases

COMPARISONS

Many predictions about the future location of the electric vehicle are made. In 2020, worldwide sales of passenger vehicle will reach 70.9 million and its 3.88 million (5.5%) will be hybrid vehicles and its 1.31 million (1.8%) will be battery electric vehicles [20]. According to the International Energy Agency (IEA) report, the battery electric and plug-in hybrid electric vehicles will increase in the coming years. As shown in figure 4, the gasoline and diesel-fueled vehicles will be withdrawn from the market by 2050 [21].

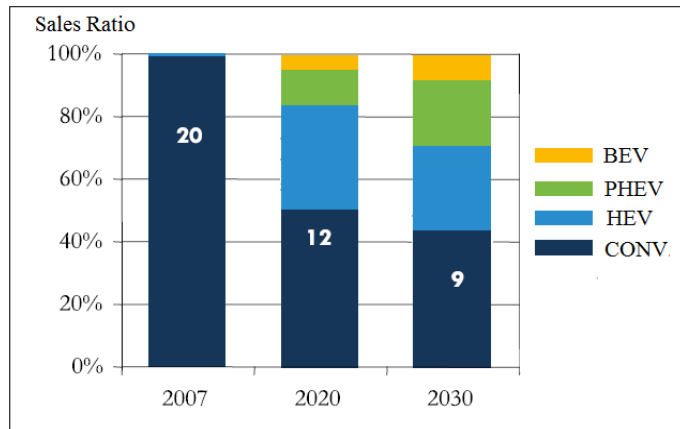

Figure 4: The vehicles to be sold to the on world [21]

Battery electric vehicles and plug-in hybrid electric vehicles are eco-friendly vehicles, as in figure 5 and figure 6. Governments used various methods about the spread of eco-friendly vehicles in the world. These are increasing the tax on conventional vehicles, incentives to eco-friendly vehicles and reducing taxes on eco-friendly vehicles [13, 22].

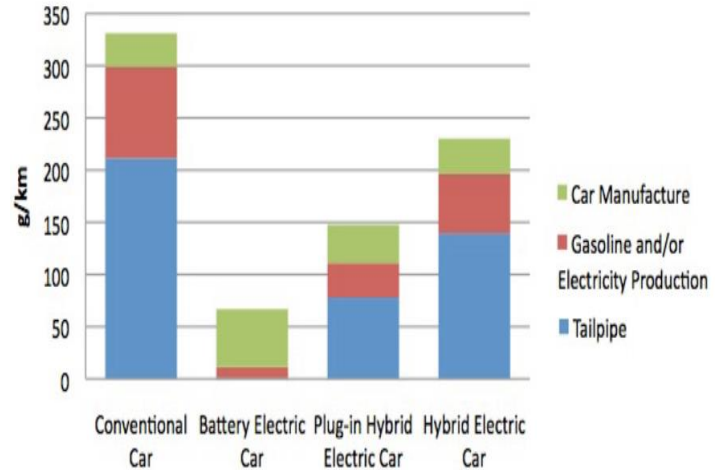

Figure 5: The greenhouse gas life-cycle results for each of the vehicle technologies [22]

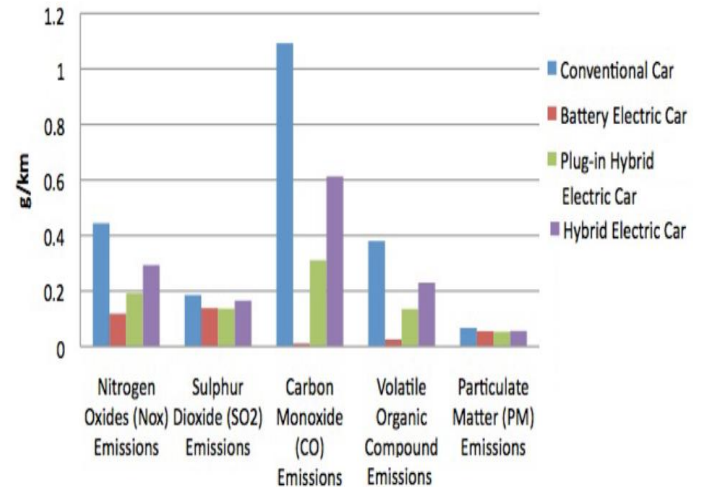

Figure 6: Life cycle air emissions for internal combustion, battery electric, plug-in hybrid electric and hybrid electric vehicles [22]

Turkey has provided tax incentives to purchase electric vehicles. Ministry of Finance Revenue Administration has decided to apply 3% excise tax for the engine power up to 85 kW for electric cars, 7% for the engine power between 85-120 kW and 15% for the engine power exceeds 120 kilowatts [23]. Recently, by date of 05.10.2016 in the official newspaper, Turkey has announced 45% discount excise tax for the electrical motor power between 50-100 kW and 55% discount excise tax for the electrical motor power 100 kW and up for the electric vehicles [24].

CONCLUSION

The problems of the electric vehicle technology, such as range, infrastructure and high production costs are overcome rapidly. Large number of small and lightweight battery electric vehicles will stand out in the city center. For the long range and large vehicles plug-in hybrid electric vehicles will have the priority.

In the next years, for charging plug-in hybrid and battery electric vehicles investment, the research and development activities on the electric grid will be widespread. Smart grid applications for these vehicles will grow and it will increase the needs of software and hardware for the battery, charge and the plug-in technology.

REFERENCES

- [1] Kundakci I. M. and H .M. Ertunc, "Acceleration Curve for Electric Cars by Electrical and Mechanical Specifications", Turkish National Meeting on Automatic Control, Denizli, Turkey, 2015.
- [2] K. G. Hoyer, "The History of Alternative Fuels in Transportation: The Case of Electric and Hybrid Cars", *Utilities Policy*, 16: 63-71, 2008.
- [3] Şenlik I "Sleeping Revolution: Electric Vehicles," *Journal of Electrical Engineering*, pp.64-67, 2015.
- [4] Kerem A., "Development of Electric Vehicle Technology and Future Prospects," *Mehmet Akif Ersoy University Journal of the Institute of Science and Technology* 5 (1): 1-13, 2014.
- [5] The Electric Taxi Company You Could Have Called in 1900, <http://www.theatlantic.com>
- [6] Chan,C.C. "The Rise and Fall of Electric Vehicles in 1828-1930," *Proceedings of the IEEE*, 101(1):206 – 212, 2013
- [7] Sayın,A. A. and I. Yuksel, "Renault Fluence ElectricCar, the Modeling of Lithium-ion Battery and Battery Management," *Journal of Mechanical and Engineer*, 52 (616): 75-82, 2011.
- [8] Ünlü,N., Ş. Karahan, O. Tür, A. Yazar, E. Özsu, L. Turhan, F. Akgün, M. Tırıs, TÜBİTAK MAM, 2003.
- [9] P. Guo and P. Liu, "Research on Development of Electric Vehicles in China," *International Conference on Future Information Technology and Management Engineering*, Changzhou, China, 2010.
- [10] G. Archer "Electric Vehicles in 2013: A Progress Report," Published by Transport and Environment, 2014.
- [11] Sustainable Energy Ireland, "A Study on Costs and Benefits of Hybrid Electric and Battery Electric Vehicles in Ireland," 2007.
- [12] S. Leitman and B. Brant, "Build Your Own Electric Vehicle", The McGraw-Hill Companies Second Edition, USA, 2008.
- [13] Ustabaş, "Electric Vehicles in Terms of Micro and Macro Effects", *Marmara University, İ.İ.B. magazine*. 2:269-291, 2014.
- [14] The Massachusetts Department of Energy Resources, "An Introduction to Electric Vehicle Supply Equipment," 2014.
- [15] Automotive Technology Platform, "Electric Vehicle Working Group Report," 2010.
- [16] İ. Karakaş and M. Pekcan "Electric Vehicle Design," *Gazi University Technology Faculty, Thesis*, 2014.
- [17] M. Yıldız and T .N. Topçu "Control and Energy Management Systems in Hhybrid and Electric Vehicle," Report, 2012.
- [18] C. Musardo and B. Staccia, "Energy Management Strategies for Hybrid Electric Vehicles," *Master's Thesis*, 2003.
- [19] Boyalı "Modeling and Vontrol of Hybrid Electric Vehicles," *Doctorate Thesis*, 2008.
- [20] J. D. Power, "Drive Green 2020:More Hope than Reality?" A Special Report by J.D. Power and Associates, 2010.
- [21] R. N. Tuncay and Ö. Üstün, "Past and Future Outlook in Electric Vehicle," *Automotive Industry Committee Report*, 2012.
- [22] J. Moorhouse and K. Laufenberg, "Electric Vehicles Powering the Future," *The Pembina Institute*, 2010.
- [23] Ö. Polat, K. Yumak, M. S. Sezgin, G. Yumurtacı and Ö. Gül "Current Situations of Electric Vehicles and Charging Stations in Turkey," *6th Energy Efficiency and Quality Symposium*, Kocaeli, 2015.
- [24] The Official Newspaper, Decree of the Republic of Turkey:2016/9256, <http://www.resmigazete.gov.tr/default.aspx>